

## Cleaning the imaging area

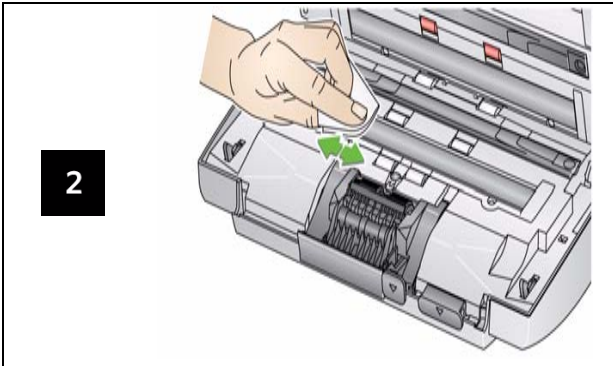

## Indicator Lights and Error Codes

When an error occurs, the red indicator will blink and one of the following codes will be displayed in the Function window.

Code	Problem	Remedy
E 0	USB cable is not connected	Be sure the USB cable is securely connected to the scanner and PC.
E 1 - E 5 E 7; E 8	Scanner failure	Turn the scanner off, then on again. Restart the scanning application and try again. If the problem persists, contact Kodak Service.
E 6	Scanner cover open	Close the scanner cover.
E 9	Document jam	Open the scanner and remove any paper in the paper path.

## Supplies and Accessories

CAT No.	Description
148 4864	Kodak Feed Rollers
173 6115	Kodak Separation Module
826 9607	Kodak Feed Module
853 5981	Kodak Roller Cleaning Pads
169 0783	Kodak Transport Cleaning Sheets
896 5519	Staticide Wipes for Kodak Scanners
868 3724	Optics Cleaner Pad
892 7717	Kodak White Background Accessory
867 7288	Kodak A4 Flatbed Accessory
863 6870	Kodak Black Background Accessory for A4
179 6747	Kodak A3 Flatbed Accessory

EASTMAN KODAK COMPANY  
 343 State Street  
 Rochester, New York 14650 U.S.A.  
 A-61631 / Part #8F9723 June, 2009  
 © Eastman Kodak Company, 2009  
 TM: Kodak



## i1200/i1300 Plus Series Scanners



Reference Guide

## Kodak Service & Support

[www.kodak.com/go/disupport](http://www.kodak.com/go/disupport)

**1.800.822.1414**  
 (US&C only; all other regions, contact your local Kodak Support Center)

When contacting support, have the following available:

- A description of your problem
- Scanner model and serial number
- Computer configuration
- Software application you are using

## Cleaning the rollers

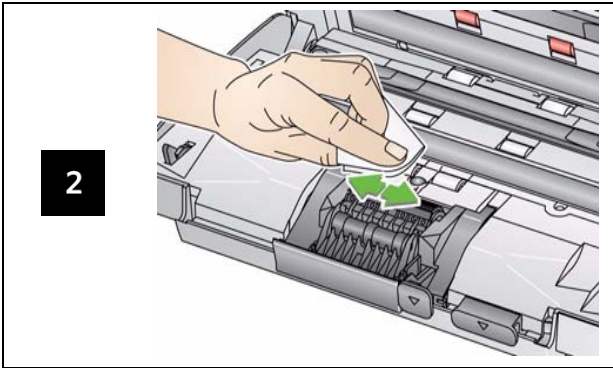

**IMPORTANT:** The Roller Cleaning Pad contains sodium lauryl ether sulfate which can cause eye irritation. Refer to the MSDS for more information.

## Cleaning and replacing the separation module

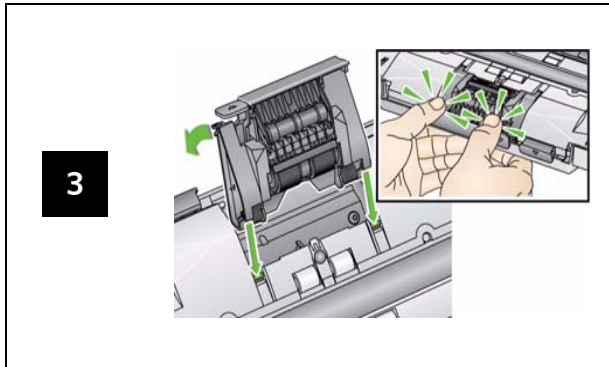
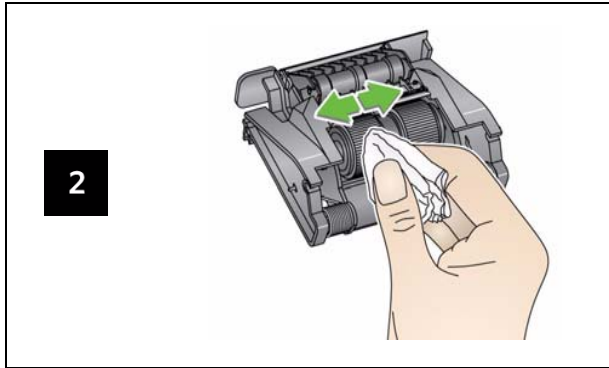
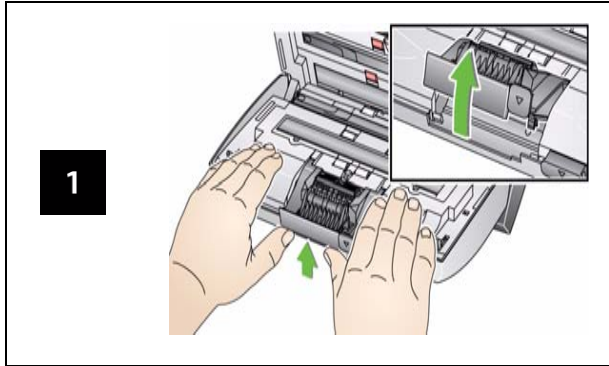

## Cleaning and replacing the feed module

